

High Definition ANPR Network Camera

The Rapiet FHD:IP is an H.264 1080p FHD resolution ANPR network camera with fully motorised varifocal lens for both IR and colour overview cameras. Configurable H.264 recognition streams ensure high quality images. Built in maxIRange™ pulsed IR lighting offers 3-50m IR performance for day and night use on high speed moving traffic.



Profile-S Compliant

Support for standard networking solutions



Single Package

ANPR & Overview network cameras in the same enclosure



High Quality Images

Best quality configurable video streams



Performance

30 FHD 1980 x 1080p images per second



Zoom Cameras

Controllable for the perfect field of view



Illumination

Pulsed illumination with control capabilities over network



Powerful IR

For true day/night number plate recognition up to 50m



Control

Full control and feedback of network cameras and IR settings



Multi-Lane

High resolution images providing excellent recognition

FHD:IP

HIGH DEFINITION ANPR NETWORK CAMERA

Intelligence to Capture 3 Lanes



High Definition ANPR Network Camera

The Rapier FHD:IP provides third party ANPR software with up to thirty 1080p images per second from both the ANPR and Overview camera modules. This industry standard output is H.264 to integrate with standard video network architectures.

The video streams, control protocol and power POE+ are all presented on a single Ethernet connection, simplifying the installation process to being a single cable from a switch or injector.

The Rapier FHD:IP 12 x Optical Zoom, provides recognition streams suitable for capture of up to 8m lane widths and is simple to set up for perfect field of view at distances from 6m up to 50m. Setup is performed using the camera's API/web pages or from an H.264 control device.

The camera's housing is made of high quality machine milled aluminium and is fully sealed to IP68. Further purged for the removal of moisture for trouble free images and long life performance.



FHD:IP

PROFILE S COMPLIANT, DUAL ANPR HD NETWORK CAMERA TO SEAMLESSLY INTEGRATE WITH AN EXISTING INFRASTRUCTURE.



Technical Data

SPECIFICATIONS

Recognition Range	Capture of up to 8m of traffic lanes at 3m to 50m (850nm IR on EU retro-reflective plates)
Motorised lenses	12 x Optical motorized zoom (7.00mm-84mm), focus and automatic iris control, Lens equivalent 51.1° to 5.0° Horizontal Field of View
IR illumination	4 pulsed LED arrays with lenses (850nm standard. White light, 740nm or 940nm optional)
Image sensor (ANPR and Overview)	Two cameras: 1/1.8" Progressive Scan Global Shutter CMOS 3.19MP 2064 (H) x 1544 (V) pixels
Low light	ANPR: 0.0 Lux with IR illumination OV: 0.1/0.006 Lux (Colour/B&W (no IR Cut) selectable)
Shutter / Iris	1/50 to 1/10,000 / F1.4 (wide) to F4.2 (tele)
Optical filters	IR: Bandpass matched to LEDs OV: Day/Night IR Cut Filter
Camera control	Via H.264 profile S or direct commands
Video compression	H.264 high profile, dual stream, AVI format; 0.1M~6Mbps bit rate adjustable; 1~30fps adjustable frame rate from encoder; quality and GOP adjustment available
Resolutions	Main stream: 1980x1080 @ 30fps; sub streams available: 1280x720, 704x576, 352x288
Network	Single RJ45 presentation of both streams; Support RTSP/FTP/PP-POE/DHCP/DDNS/NTP/UPnP
Configuration	Support web page remote configuration

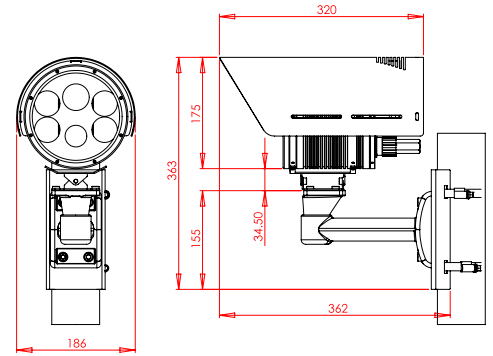

PHYSICAL

Operating Voltage	11 – 15 VDC protected or PoE+ (IEEE 802.3at)
Network connection	10/100 Base-T physical
Power Consumption	Nominally 20W – Peak 25W (during power up/zoom)
Size (WxHxD)	163 x 163 x 145mm (cylindrical) excluding connectors, mount and sunshield
Weight	2.5kg excluding mount and sunshield
Enclosure	IP68 hermetically sealed. Hard anodized aluminium with mount options
Temperature / Humidity	-20° to 50°C ambient (Operating) / 0% - 100% RH (sealed)

SERVICE

Customer Service	Friendly, helpful service for product ordering and repair ret
Technical Support	Comprehensive pre and post-sale technical support for full life of the produ
Warranty	12 month warranty, extended warranties and factory repair/replacement options available
Long Term Supply	Complete support for the life of the product
Training	Comprehensive product training available